

NO.	ECN NO.	DESCRIPTION	REV.	DRAW	DATE
1					
2					

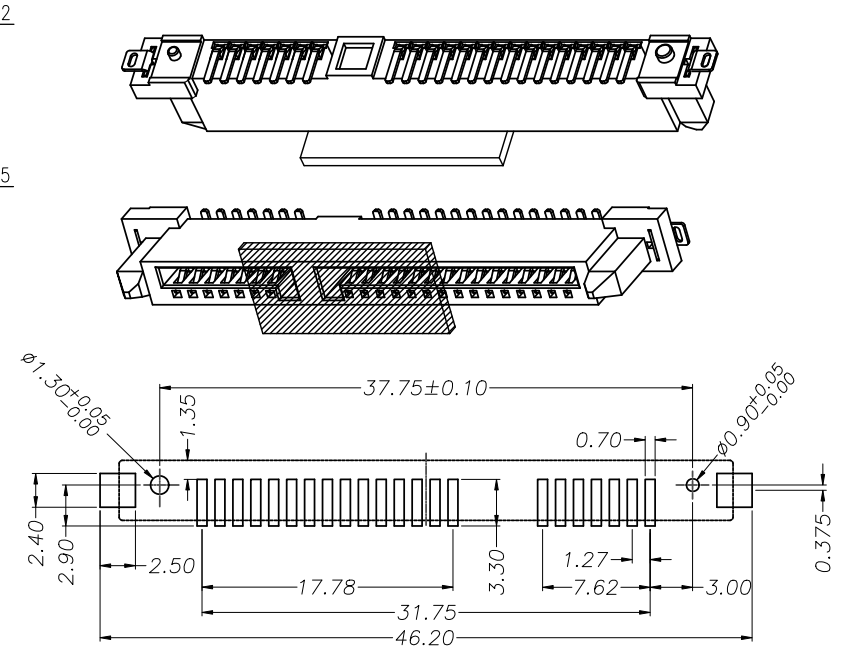
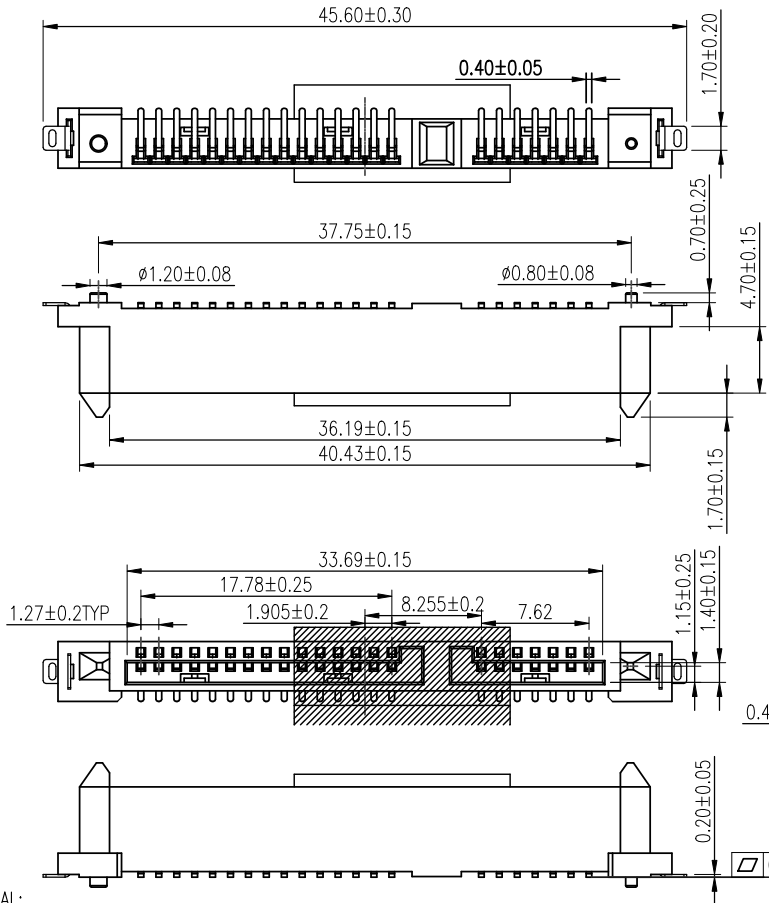

RECOMMENDED PCB LAYOUT
UNLESS TOLERANCE: +/−0.05

NOTES:
1.MATERIAL:
HOUSING: LCP 30% G/F UL 94V COLOR:BLACK
CONTACT: PHOSPHOR BRONZE
PEG: BRASS ,
2.FINISH:
CONTACT:GOLD (SEE NOTES) PLATING ON CONTACT AREA
NICKEL UNDERPLATING OVER ALL;
TIN PLATING ON SOLDERTAILS,
PEG: TIN PLATING ON SOLDERTAILS
NICKEL UNDERPLATING OVER ALL
3.RoHS COMPLIANT.
4. IR REFLOW:
THE PEAK TEMPERATURE ON THE BOARD SHALL
BE MAINTAINED FOR 10 SECONDS AT 260±5°C.
5.OPERATING TEMPERATURE:−45°C TO +85°C;
6.STOCKPILE TEMPERATURE:−20°C TO +60°C

99 126-XX M XX 9
PLATING CODE:
05: Au 0.5~1u"; 19: Au15u";
PLATING SPECIFICATION:
M: HALF THE GOLD TIN
TYPE SERIAL NUMBER
PRODUCT SERIAL NUMBER
USB TYPE

产品客户图 Customer Drw		GLGNET® 深圳市方向电子股份有限公司 SHEN ZHEN GLGNET ELECTRONICS CO.,LTD.					
未注公差 TOLERANCE UNLESS OTHERWISE SPECIFIED	.X ±0.35 .XX ±0.30 .XXX ±0.15 X° ±3°	设计 DESIGN	胡国亮	20220914	品名 TITLE	SATA 7+15 SMT 180度+接地片	
比例 SCALE	1:1	角法 PROJ.	设计 DESIGN	胡国亮	20220914	品名 TITLE	SATA 7+15 SMT 180度+接地片
张数 SHEET	1/1	大小 SIZE	A4	校对 CHECKED		料号 ITEM NO.	170253-00121 (99126-00M199)
单位 UNIT	mm	版本 REV.	A0	核准 APPROVED		图号 DWG NO.	GLG-170253