

NO.	ECN NO.	DESCRIPTION	REV.	DRAW	DATE
1					
2					
3					

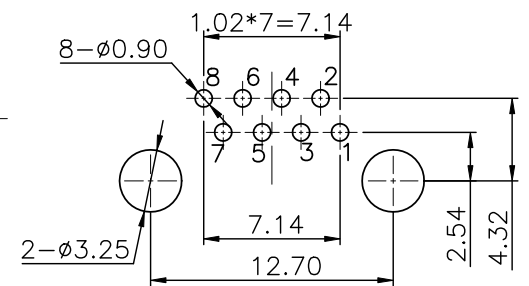

RECOMMENDED P.C.B LAYOUT TOP VIEW
T=1.0~1.6(COMPONENT SIDE TOLERANCE±0.05)

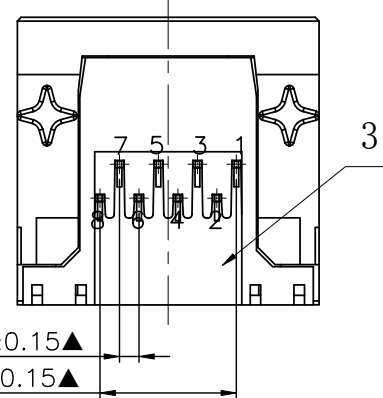
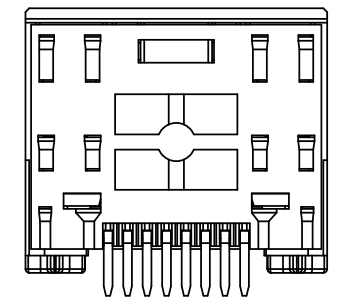
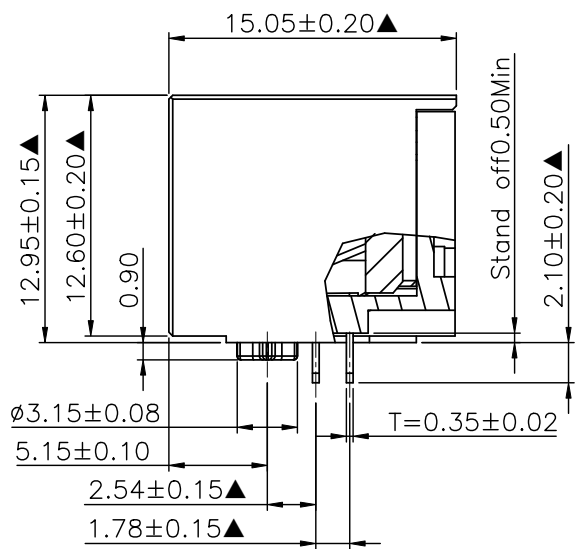
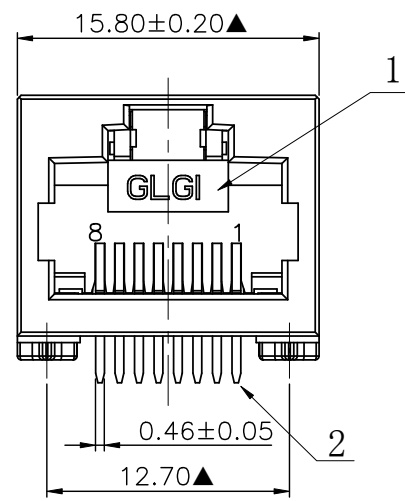
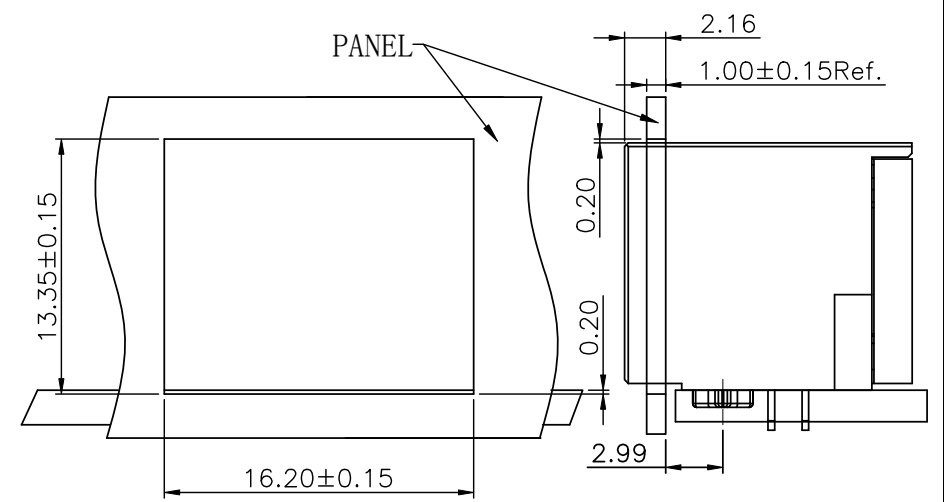

RECOMMENDED PANEL CUTOUT

注:
 材质, 电镀:
 1. 塑壳:PBT+30%G.F UL94V-0, 114C黄.
 2. 端子:T0.35*0.46 Phosphor Bronze Selective gold Plating and Over Nickel, Tails Matt Sn (ROHS).
 3. 针座:PBT+30%G.F UL94V-0, 114C黄.
 4. 满足低温回流焊工艺, 200°C T=10S;
 ※MATES WITH MODULAR PLUG CONFORMING TO FCC PART 68, SUBPART F.
 ※凡注▲记号者, 为重点尺寸。

41209-60 X X X 1
 规格流水码
 电镀代码
 M:半金雾锡
 S:半金亮锡
 -31-30u"
 -32-15u"
 -34-6u"
 -35-3u"
 -36-1u"

产品客户图 Customer Drw		设计		品名	
未注公差 TOLERANCE UNLESS OTHERWISE SPECIFIED	.X ±0.35 .XX ±0.25 .XXX ±0.15 X° ±3°	设计 DESIGN		品名 TITLE	5631-Q-8C-6A-60
比例 SCALE	1:1	角法 PROJ.		料号 ITEM NO.	41209-60XXX1
张数 SHEET	1/1	大小 SIZE	A4	图号 DWG NO.	GLG-W0-701
单位 UNIT	mm	版本 REV.	A4	核准 APPROVED	

GLGNET 深圳市方向电子股份有限公司
 SHEN ZHEN GLGNET ELECTRONICS CO.,LTD.