

NO.	ECN NO.	DESCRIPTION	REV.	DRAW	DATE
1					
2					
3					

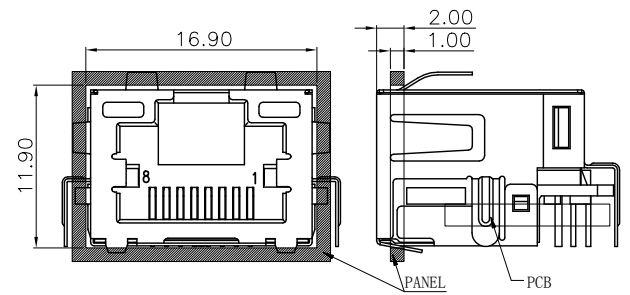

Recommended panel cutout

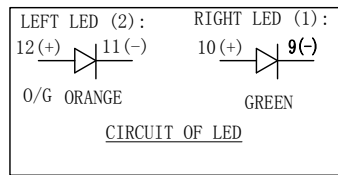
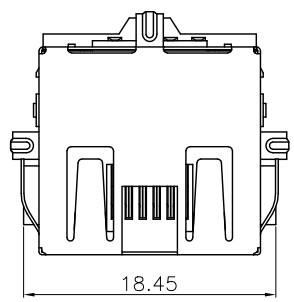
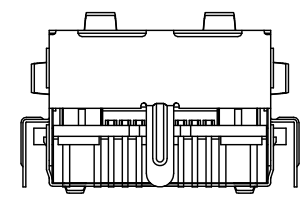
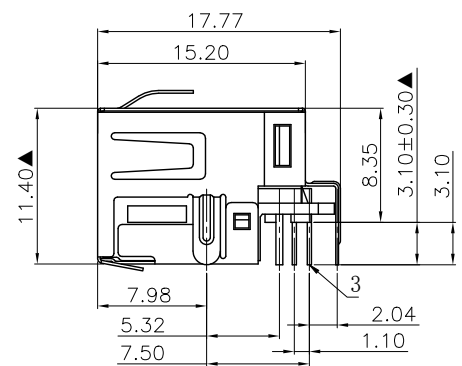
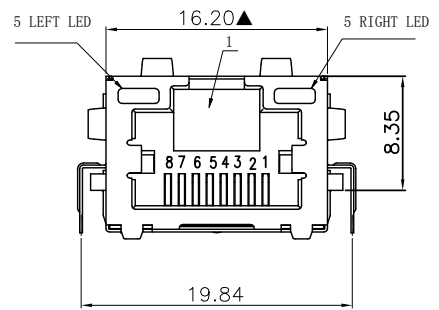

42000-15 X X X 1

规格流水码

电镀规格
 S 半金亮锡
 M 半金雾锡

电镀代码
 05-1u"
 09-2u"
 11-3u"
 15-6u"
 19-15u"
 23-30u"
 24-50u"
 34-6u"
 32-15u"
 31-30u"

- NOTES:
- HOUSING: LCP, UL 94V-0, COLOR- BLACK
 - PLUG:LCP, UL 94V-0, COLOR-BLACK
 - CONTACT: Phosphor Bronze, 0.30 mm ,
 - SHELL: COPPER ALLOY, 50 μ"MIN. NICKEL PLATED OVERALL
 - LED MUST BE THE HIGH TEMPERATURE MATERIAL
- *MATES WITH MODULAR PLUG CONFORMING TO FCC PART 68, SUBPART F.
 ※凡注"▲"记者者, 为重点尺寸。

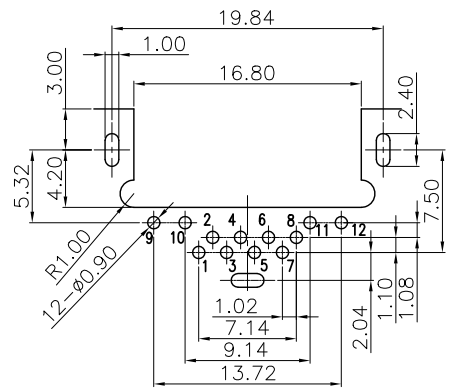
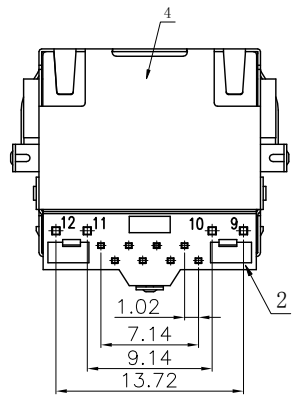

RECOMMENDED PCB LAYOUT (TOP VIEW)
 (ALL TOLERANCES ARE ±0.05)

产品客户图 Customer Drw		TOLERANCE UNLESS OTHERWISE SPECIFIED		GLGNET® 深圳市方向电子股份有限公司 Shenzhen GLGNET Electronics Co.,LTD.	
未注公差	.X	±0.35	设计 DESIGN	品名 TITLE	6221-Q-S-K6-L-8C-I-15 (O/G)
	.XX	±0.25			
	.XXX	±0.15			
比例 SCALE	1:1	角法 PROJ.	设计 DESIGN	品名 TITLE	6221-Q-S-K6-L-8C-I-15 (O/G)
张数 SHEET	1/1	大小 SIZE	A4	校对 CHECKED	料号 ITEM NO.
单位 UNIT	mm	版本 REV.	P0	核准 APPROVED	图号 DWG NO.
					42000-15XXX1
					GLG-110416