

NO.	ECN NO.	DESCRIPTION	REV.	DRAW	DATE
1	-	INITIAL	1	YW PENG	2019/01/19

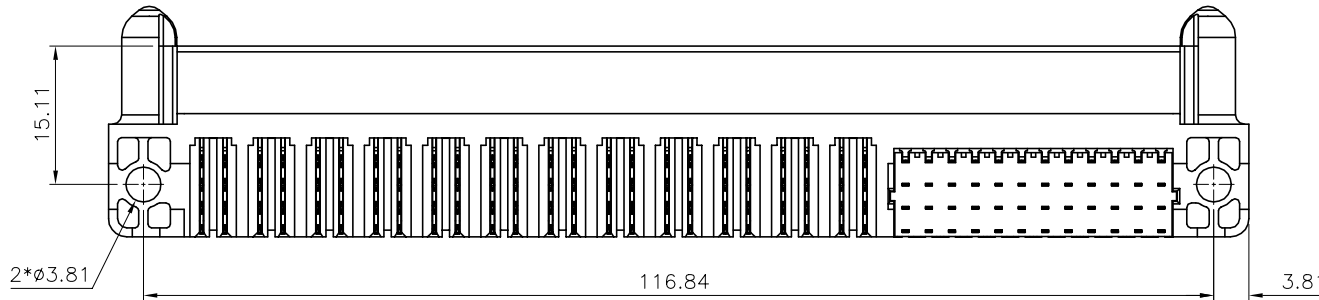
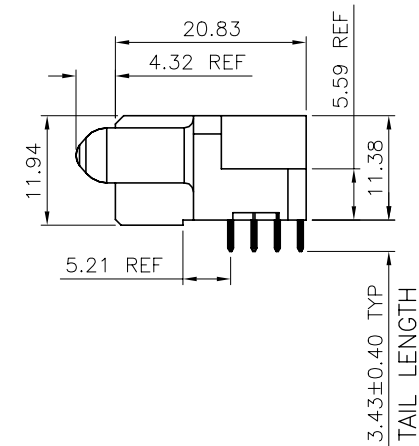
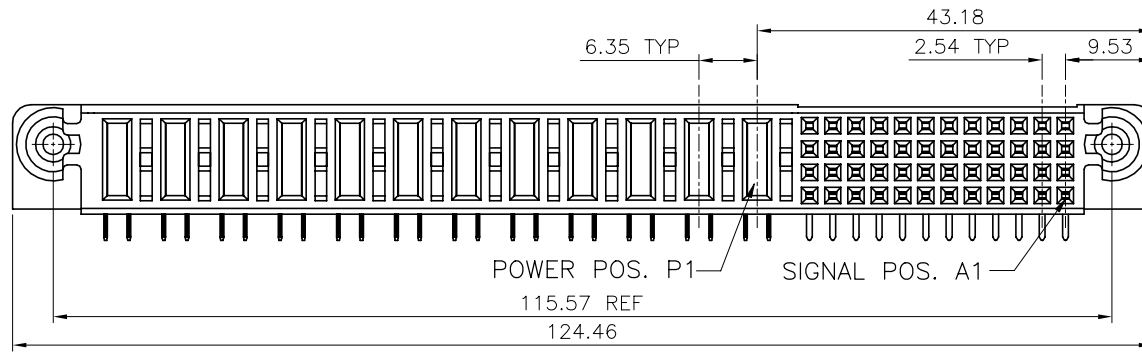
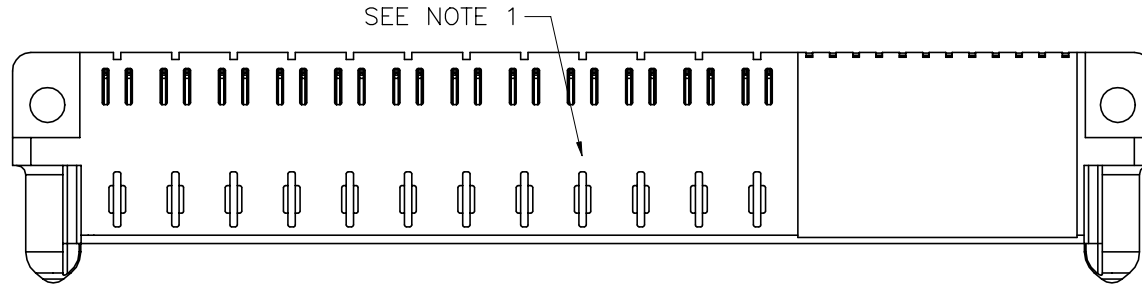

PRELIMINARY

产品客户图 Customer Drw				GLGNET® 深圳市方向电子股份有限公司 SHEN ZHEN GLGNET ELECTRONICS CO.,LTD.			
未注公差 TOLERANCE UNLESS OTHERWISE SPECIFIED	.X .XX .XXX X°	±0.35 ±0.25 ±0.15 ±2°		设计 DESIGN	YW PENG	品名 TITLE	48S+12P RA STB RECEPTACLE W/O HOLD DOWN
比例 SCALE	1:1	角法 PROJ.	设计 DESIGN	校对 CHECKED	YW PENG	料号 ITEM NO.	72A3-120048-A002
张数 SHEET	1/3	纸张 SIZE	核准 APPROVE	HT ZHANG	图号 DWG NO.		GLG-72-008

8		7		6		5		4		3		2		1																			
PRODUCT NO.		ROWS		POWER				SIGNAL				NO.	ECN NO.	DESCRIPTION	REV.	DRAW	DATE																
72A3-120048-A002		D		P12	P11	P10	P9	P8	P7	P6	P5	P4	P3	P2	P1	12	11	10	9	8	7	6	5	4	3	2	1	1	-	INITIAL	1	YW PENG	2019/01/19

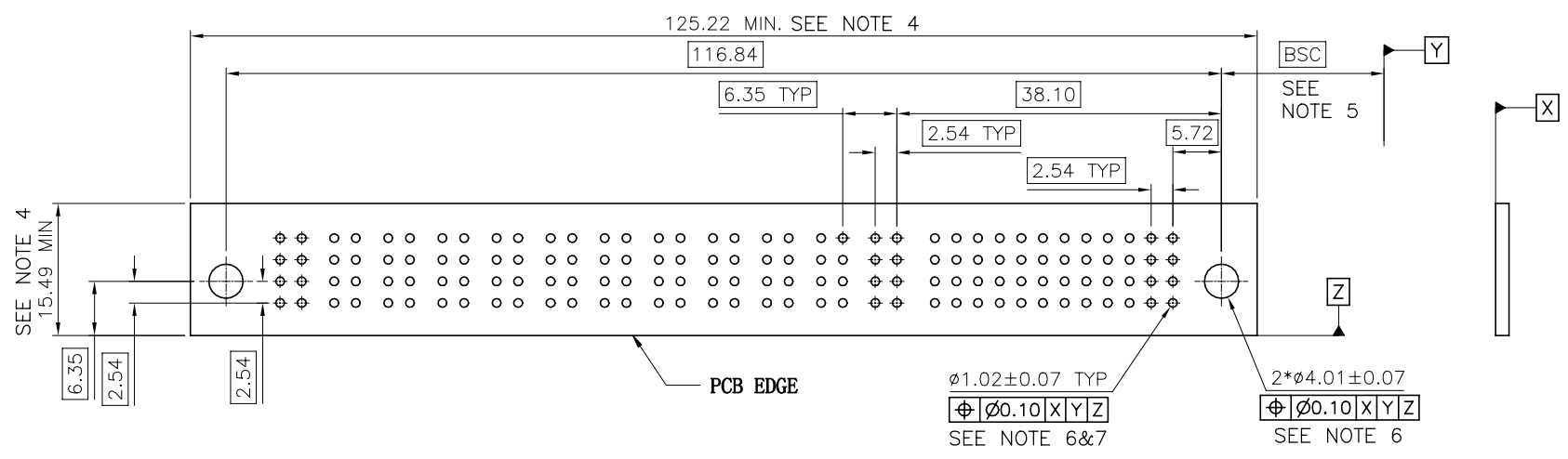

RECOMMENDED PCB LAYOUT

PRELIMINARY

U	SIGNAL CONTACT	N/A
T	SIGNAL CONTACT	N/A
S	SIGNAL CONTACT	N/A
R	SIGNAL CONTACT	N/A
RC	POWER CONTACT	1.07
LC	POWER CONTACT	1.07
CODE	DESCRIPTION	MATING LENGTH

产品客户图 Customer Drw				GLGNET® 深圳市方向电子股份有限公司 SHEN ZHEN GLGNET ELECTRONICS CO.,LTD.															
未注公差 TOLERANCE UNLESS OTHERWISE SPECIFIED	.X	±0.35		比例 SCALE	1:1	角法 PROJ.	设计 DESIGN	YW PENG	品名 TITLE	48S+12P RA STB RECEPTACLE W/O HOLD DOWN									
	.XX	±0.25			张数 SHEET			2/3		纸张 SIZE	A4	校对 CHECKED	YW PENG	料号 ITEM NO.	72A3-120048-A002				
	.XXX	±0.15						单位 UNIT			mm		版本 REV.		1	核准 APPROVE	HT ZHANG	图号 DWG NO.	GLG-72-008
	X°	±2°																	

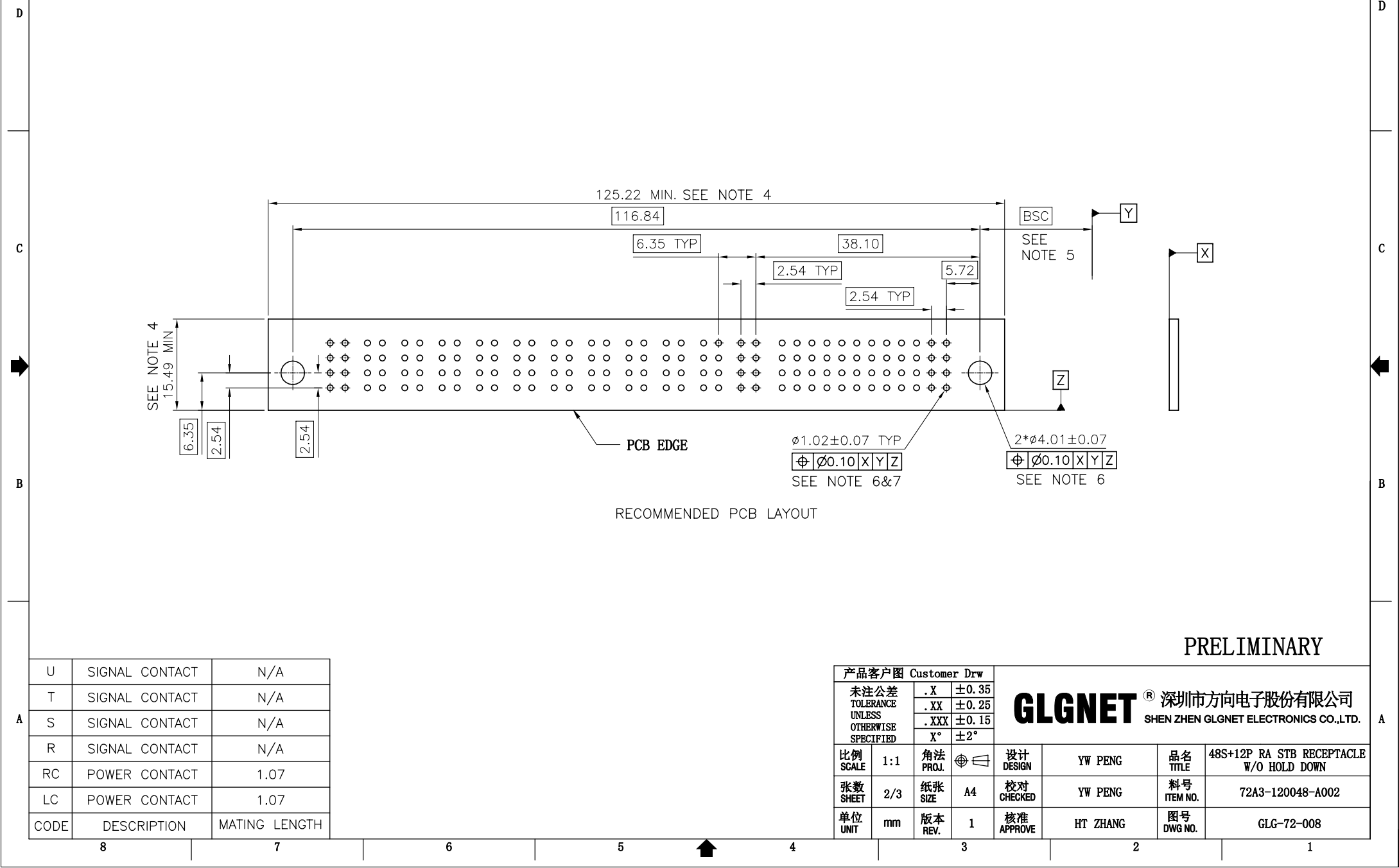

3		2		1	
NO.	ECN NO.	DESCRIPTION	REV.	DRAW	DATE
1	-	INITIAL	1	YW PENG	2019/01/19

NOTES:

- ① "GLGNET" AND DATE CODE TO BE MARKED ON THIS SURFACE.
2. MATERIALS:  
HOUSING - GLASS FILLED HIGH TEMP THERMO PLASTIC, UL94V-0.  
POWER CONTACTS - HIGH CONDUCTIVITY COPPER ALLOY.  
SIGNAL CONTACTS - COPPER ALLOY.
3. CONTACT PLATING: NOBLE METAL PLATING ON FUNCTIONAL AREA FOR SIGNAL AND POWER CONTACTS.
- ④ MECHANICAL CONNECTOR KEEP OUT ZONE.
- ⑤ DATUM AND BASIC DIMENSIONS ESTABLISHED BY CUSTOMER.
- ⑥ PCB - ALL HOLE DIAMETERS ARE FINISHED HOLE SIZES.
- ⑦ PCB - 1.150±0.025 DRILLED HOLE PLATED WITH 7.62um MIN Sn OVER 25.4um-76.2um Cu PLATING TO ACHIEVE A 1.02±0.07mm FINISHED HOLE.
8. PRODUCT SPECIFICATION: GLG-AR048.

PRELIMINARY

产品客户图 Customer Drw				GLGNET <sup>®</sup> 深圳市方向电子股份有限公司 SHEN ZHEN GLGNET ELECTRONICS CO.,LTD.			
未注公差 TOLERANCE UNLESS OTHERWISE SPECIFIED	.X	±0.35	设计 DESIGN	YW PENG	品名 TITLE	48S+12P RA STB RECEPTACLE W/O HOLD DOWN	
	.XX	±0.25					
	.XXX	±0.15					
	X°	±2°					
比例 SCALE	1:1	角法 PROJ.	⊕	校对 CHECKED	YW PENG	料号 ITEM NO.	72A3-120048-A002
张数 SHEET	3/3	纸张 SIZE	A4	核准 APPROVE	HT ZHANG	图号 DWG NO.	GLG-72-008
单位 UNIT	mm	版本 REV.	1				