

NO.	ECN NO.	DESCRIPTION	REV.	DRAW	DATE
1					
2					
3					

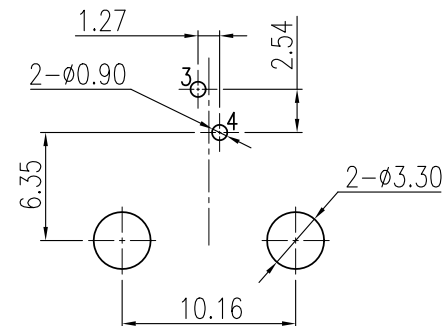

RECOMMENDED P.C.B LAYOUT TOP VIEW  
(COMPONENT SIDE TOLERANCE ±0.05)

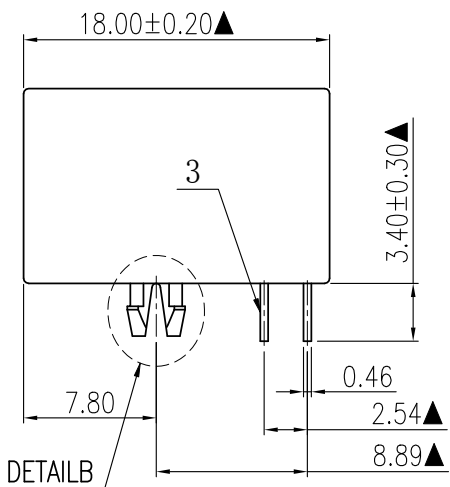
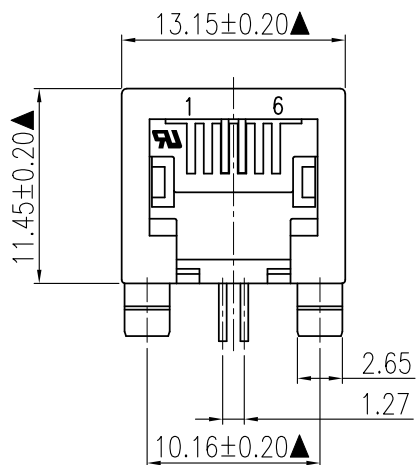
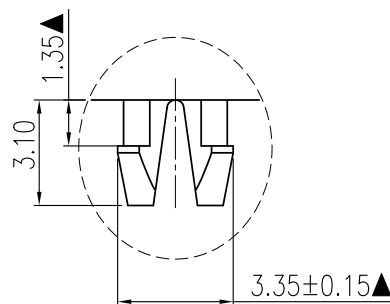
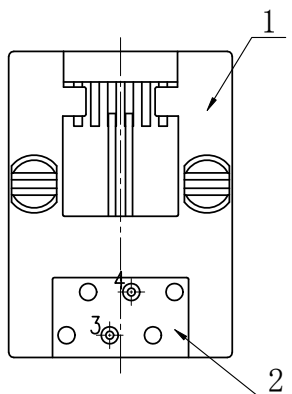

DETAILB  
SCALE: 2:1

11056-X X G X X 1  
规格流水码 | 电镀代码  
05-G/F  
11-3u"  
15-6u"  
19-15u"  
23-30u"

**MATERIALS:**

1. Housing: PBT 冷灰3U UL94V-0. (RoHS)
  2. Insert: PBT 冷灰3U UL94V-0. (RoHS)
  3. Contact: 0.46mm DIA Phosphor Bronze  
gold Plating Over Nickel, 镀金G/F 镍底50-100u" (RoHS)
- ※凡标注▲记号者, 为重点尺寸.

产品客户图 Customer Drw		GLGNET® 深圳市方向电子股份有限公司 Shenzhen GLGNET Electronics Co.,LTD.				
未注公差 TOLERANCE UNLESS OTHERWISE SPECIFIED	.X	±0.35	设计 DESIGN	品名 TITLE	5523-1-6P2C-12	
	.XX	±0.25				
	.XXX	±0.15				
	X°	±2°				
比例 SCALE	1:1	角法 PROJ.	设计 DESIGN	品名 TITLE	5523-1-6P2C-12	
张数 SHEET	1/1	大小 SIZE	A4	校对 CHECKED	料号 ITEM NO.	11056-12GXX1
单位 UNIT	mm	版本 REV.	P0	核准 APPROVED	图号 DWG NO.	GLG-110028