

NO.	ECN NO.	DESCRIPTION	REV.	DRAW	DATE
1					
2					
3					

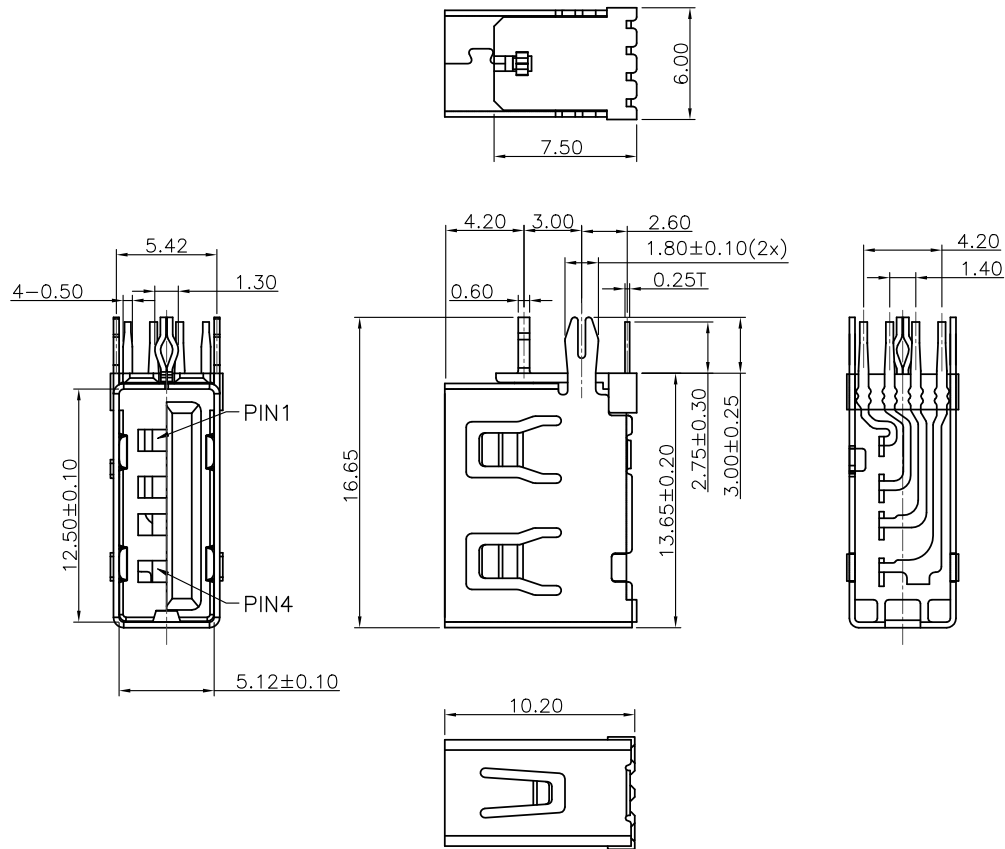

1.MATERIAL SPECIFICATION:

- 1-1.HOUSING:PBT/LCP; UL94 V-0 BLACK.
- 1-2.CONTACTS: COPPER ALLOY T=0.25mm.
- 1-3.SHELL: SPCC T=0.30mm.

2.PLATING SPECIFICATION:

- 2-1.CONTACTS:
Ni 50u" . UNDER PLATED OVERALL.
Au G/F PLATED ON THE FUNCTIONAL AREA OF CONTACT,80u" TIN PLATED ON SOLDER AREA.
- 2-2.SHELL:
Ni 50u" . PLATED OVERALL.

3.MECHANICAL PERFORMANCE,

- 3-1.INSERTION FORCE: 3.5kgf MAX
- 3-2.REMOVAL FORCE: 1.0kgf MIN. AFTER THE TEST 0.8kgf
- 3-3.DURABILITY: 1500 CYCLES.

4.ELECTRICAL PERFORMANCE,

- 4-1.INSULATION RESISTANCE: 1000MΩ MIN
- 4-2.DIELECTRIC WITHSTAND VOLTAGE,AC 500V FOR 1 MINUTE.

5.MATES WITH MODULAR PLUG CONFORMING TO USB2.0,SUBPART F.

6.RoHS COMPLIANT.

7.THT REFLOW:

THE PEAK TEMPERATURE ON THE BOARD SHALL BE MAINTAINED FOR 5 SECONDS AT 245±5°C.

8. PART NUMBER NOTE:

08105-0X S 05 9

- RoHS COMPLIANT.
- PLATING CODE:
- 05: AuG/F
- PLATING SPECIFICATION:
- M: HALF THE GOLD MATTE TIN
- S: HALF THE GOLD BRIGHT TIN
- TYPE SERIAL NUMBER
- PRODUCT SERIAL NUMBER
- USB TYPE

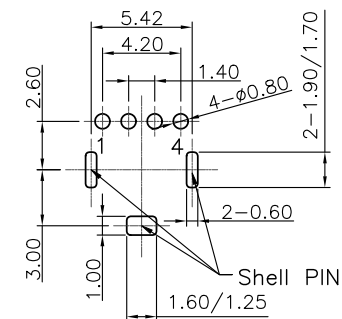

RECOMMENDED PCB LAYOUT

Pin Assignments

Pin Number	Signal Name	产品客户图 Customer Drw		GLGNET® 深圳市方向电子股份有限公司 SHEN ZHEN GLGNET ELECTRONICS CO.,LTD.			
1	VBUS	未注公差 TOLERANCE UNLESS OTHERWISE SPECIFIED	X ±0.45 X ±0.35 XX ±0.25 X° ±3°	设计 DESIGN		品名 TITLE	USB-UP-DIP90-M-2A-4P-D-00
2	D-	比例 SCALE	1:1	角法 PROJ.		料号 ITEM NO.	08105-00S059
3	D+	张数 SHEET		大小 SIZE	A4	图号 DWG NO.	GLG-WC-XXX
4	GND	单位 UNIT	mm	版本 REV.	A0	核准 APPROVED	
Shell	Shield						