

NO.	ECN NO.	DESCRIPTION	REV.	DRAW	DATE
1		产品结构优化	A1	YJH	20220722
2					
3					

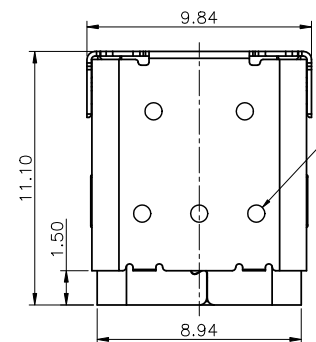

Spot welding position is only for your reference

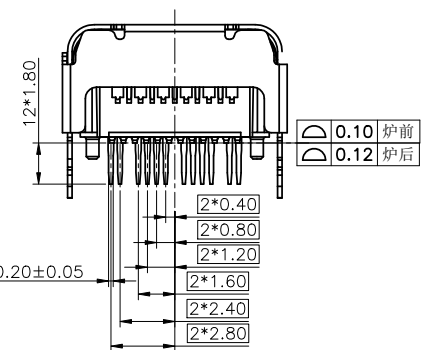
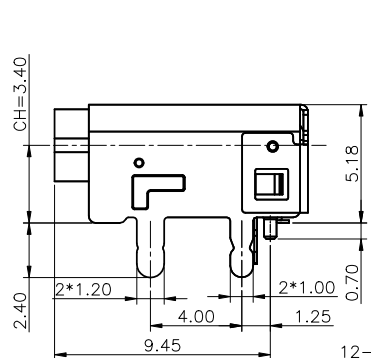
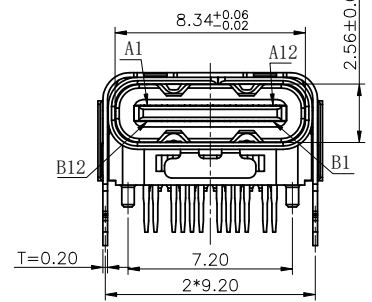
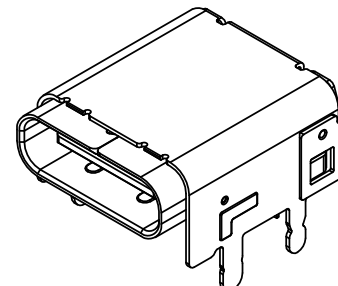

0.10 炉前  
0.12 炉后

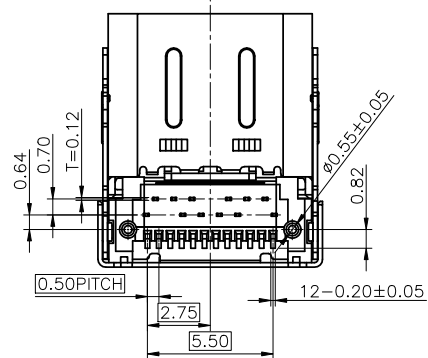

7. PART NUMBER NOTE:

08619-00 X XX 9  
 RoHS COMPLIANT.  
 PLATING CODE:  
 05: Au Fu"; 11: Au3u"; 19: Au 15u";  
 23: Au 30u"  
 PLATING SPECIFICATION:  
 M: HALF THE GOLD MATTE TIN  
 J: HALF THE GOLD MATTE TIN  
 TYPE SERIAL NUMBER  
 PRODUCT SERIAL NUMBER  
 USB TYPE

NOTE:  
 1. MATERIAL SPECIFICATION:  
 1-1. HOUSING: HIGH TEMPERATURE RESISTANT PLASTIC, WITH 30% GLASS FILLED, UL94 V-0 BLACK.  
 1-2. CONTACTS: COPPER ALLOY  
 1-3. FRONT SHELL: STAINLESS STEEL  
 1-4. MIDDLE PLATE: STAINLESS STEEL  
 2. PLATING SPECIFICATION:  
 2-1. CONTACTS:  
 Ni 50u" MIN. UNDER PLATED OVER ALL.  
 G/Fu" Au PLATED ON THE FUNCTIONAL AREA OF CONTACT.  
 TIN PLATED ON SOLDER AREA.  
 2-2. EMI SPRING: CLEANING ONLY  
 2-3. FRONT SHELL: Ni 50u" MIN. UNDER PLATED OVER ALL.  
 2-4. MIDDLE PLATE:  
 Ni 40u" MIN. UNDER PLATED OVER ALL.  
 TIN 50u" Min PLATED ON SOLDER AREA.  
 3. MECHANICAL PERFORMANCE,  
 3-1. INSERTION FORCE: 0.5~2.0kgf.  
 3-2. REMOVAL FORCE: 0.8kgf~2.0kgf.  
 3-3. DURABILITY: 10000 CYCLES.  
 4. ELECTRICAL PERFORMANCE,  
 4-1. CURRENT RATING: 5.0A  
 VOLTAGE RATING: 5.0V  
 4-2. LLCR:  
 VBUS & GND PINS AND OTHER PINS: 40mΩ/PIN MAX.  
 SHIELD: 50mΩ/MAX.  
 LLCR MAX. CHANGE OF ALL PINS: 10mΩ.  
 4-3. INSULATION RESISTANCE: 100MΩ MIN  
 4-4. DIELECTRIC WITHSTAND VOLTAGE, AC 100V FOR 1 MINUTE.  
 5. ENVIRONMENTAL PERFORMANCE:  
 OPERATING TEMPERATURE: -25° C~+85° C.  
 6. IR REFLOW:  
 THE PEAK TEMPERATURE ON THE BOARD SHALL BE MAINTAINED FOR 10 SECONDS AT 260° C.

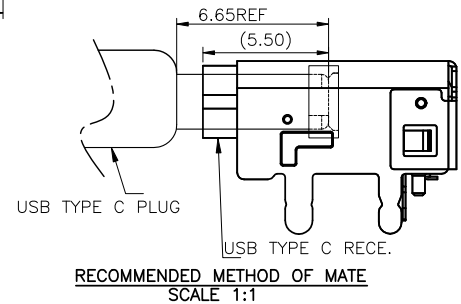

公差		X	±0.30				
未注公差 TOLERANCE UNLESS OTHERWISE SPECIFIED	.X	±0.25	<b>GLGNET</b> ® 深圳市方向电子股份有限公司 SHEN ZHEN GLGNET ELECTRONICS CO.,LTD.				
	.XX	±0.20					
	X'	±3'					
比例 SCALE	1:1	角法 PROJ.	设计 DESIGN	YJH	20220722	品名 TITLE	USB-SMT90-M-C30-24P-D-00
张数 SHEET	1/2	大小 SIZE	A4	校对 CHECKED		料号 ITEM NO.	08619-00J059
单位 UNIT	mm	版本 REV.	A1	核准 APPROVED		图号 DWG NO.	GLG-WC-XXX

NO.	ECN NO.	DESCRIPTION	REV.	DRAW	DATE
1		产品结构优化	A1	YJH	20220722
2					
3					

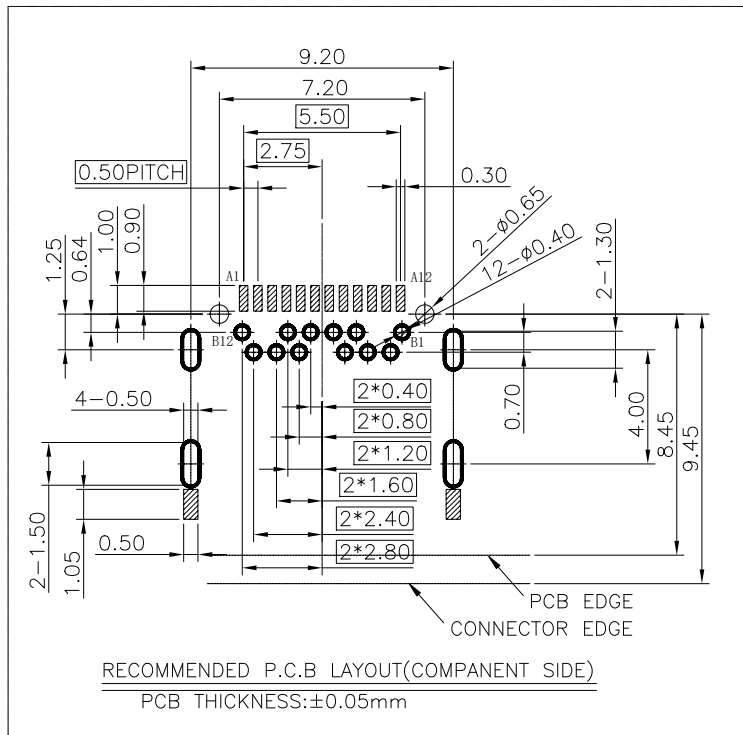

USB TYPE-C PIN ASSIGNMENTS

A1	GND	B12	GND
A2	SSTXP1	B11	SSRXP1
A3	SSTXN1	B10	SSRXN1
A4	VBUS	B9	VBUS
A5	CC1	B8	SBU2
A6	DP1	B7	DN2
A7	DN1	B6	DP2
A8	SBU1	B5	CC2
A9	VBUS	B4	VBUS
A10	SSRXN2	B3	SSTXN2
A11	SSRXP2	B2	SSTXP2
A12	GND	B1	GND
PIN	SIGNAL NAME	PIN	SIGNAL NAME

产品客户图 Customer Drw

未注公差	X	±0.35
TOLERANCE	.X	±0.30
UNLESS OTHERWISE SPECIFIED	.XX	±0.20
	X*	±3°

**GLGNET**® 深圳市方向电子股份有限公司  
SHEN ZHEN GLGNET ELECTRONICS CO., LTD.

比例 SCALE	1:1	角法 PROJ.	设计 DESIGN	YJH	20220722	品名 TITLE	USB-SMT90-M-C30-24P-D-00
张数 SHEET	2/2	大小 SIZE	校对 CHECKED			料号 ITEM NO.	08619-00J059
单位 UNIT	mm	版本 REV.	核准 APPROVED	A1		图号 DWG NO.	GLG-WC-XXX