

NO.	ECN NO.	DESCRIPTION	REV.	DRAW	DATE
1	-	MODIFY	A1	ZHIWEN	2020/03/10

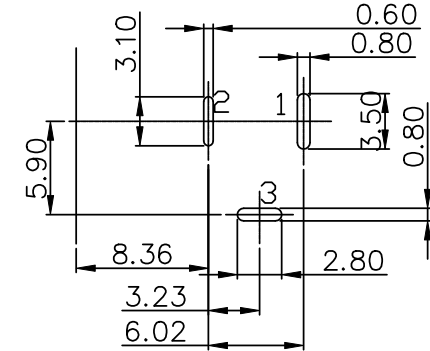

RECOMMENDED PCB LAYOUT(TOP VIEW)
DEFAULT TOLERANCE ±0.05

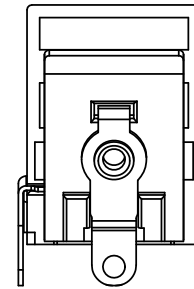
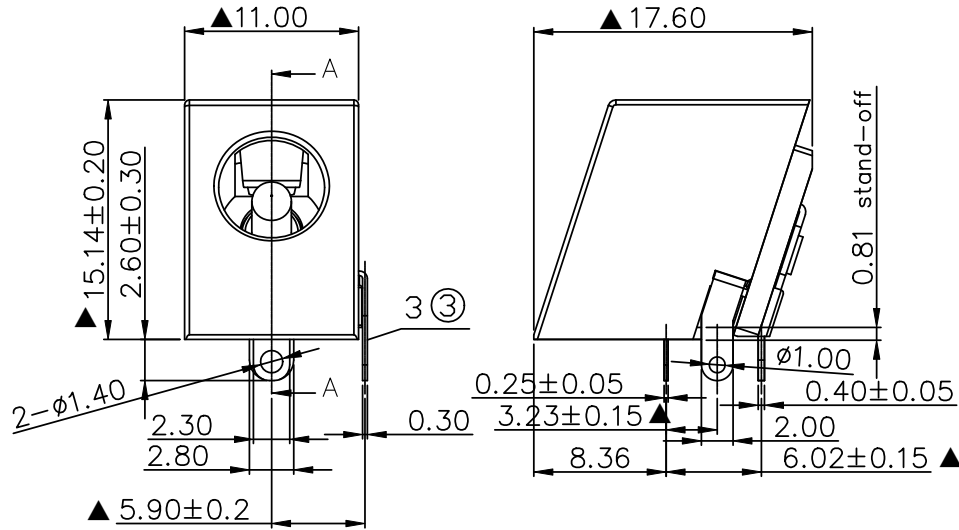
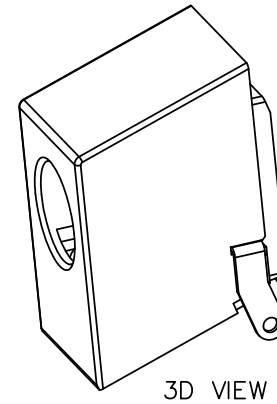

3D VIEW

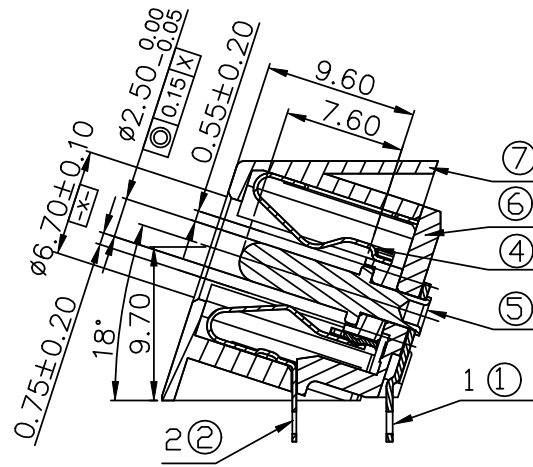

A-A
1:1

- MECHANICAL PERFORMANCE,
 - 1-1.INSERTION FORCE: 50N MAX
 - 1-2.REMOVAL FORCE: 6N MIN
 - 1-3.DURABILITY: 500 CYCLES.
 - ELECTRICAL PERFORMANCE,
 - 2-1.LLCCR: 30mΩ MAX.
 - 2-2.INSULATION RESISTANCE: 500MΩ MIN
 - 2-3.DIELECTRIC WITHSTAND VOLTAGE,AC 1500V FOR 1 MINUTE.
 - 2-4.CURRENT RATING:3A
 - 2-5.VOLTAGE: 50V
 - RoHS COMPLIANT.
 - OPERATING TEMPERATURE: -40°C TO +95°C;
 - STOCKPILE TEMPERATURE: -10°C TO +60°C
- MARK "▲" IS THE KEY SIZE

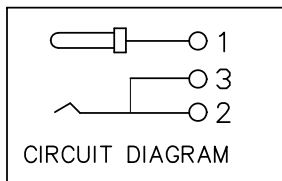

⑦	HOUSING	1	PA10T	BLACK
⑥	COVER	1	PA10T	BLACK
⑤	CEN PIN	1	H65	Matte Sn 100U"Over Ni 50U"
④	TERMIAL 4#	1	SUS301	Matte Sn 100U"Over Ni 50U"
③	TERMIAL 3#	1	C2680R-EH	Matte Sn 100U"Over Ni 50U"
②	TERMIAL 2#	1	SUS301	Matte Sn 100U"Over Ni 50U"
①	TERMIAL 1#	1	C2680R-EH	Matte Sn 100U"Over Ni 50U"
No.	PART NAME	QTY	MATERIAL(THICK)	

产品客户图 Customer Drw		TOLERANCE UNLESS OTHERWISE SPECIFIED		GLGNET® 深圳市方向电子股份有限公司 SHEN ZHEN GLGNET ELECTRONICS CO.,LTD.	
.X	±0.35	.XX	±0.25	设计 DESIGN	ZHIWEN
.XXX	±0.15	X°	±2°	校对 CHECKED	YW PENG
比例 SCALE	1:1	角法 PROJ.	设计 DESIGN	设计 DESIGN	ZHIWEN
张数 SHEET	1/1	大小 SIZE	A4	校对 CHECKED	YW PENG
单位 UNIT	mm	版本 REV.	A1	核准 APPROVED	HT ZHANG
				设计 DESIGN	ZHIWEN
				日期 DATE	2020/03/10
				品名 TITLE	DC-DIP90-25-3P-G-60
				料号 ITEM NO.	01065-60T049 (170004-00121)
				图号 DWG NO.	GLG-DDC-059